

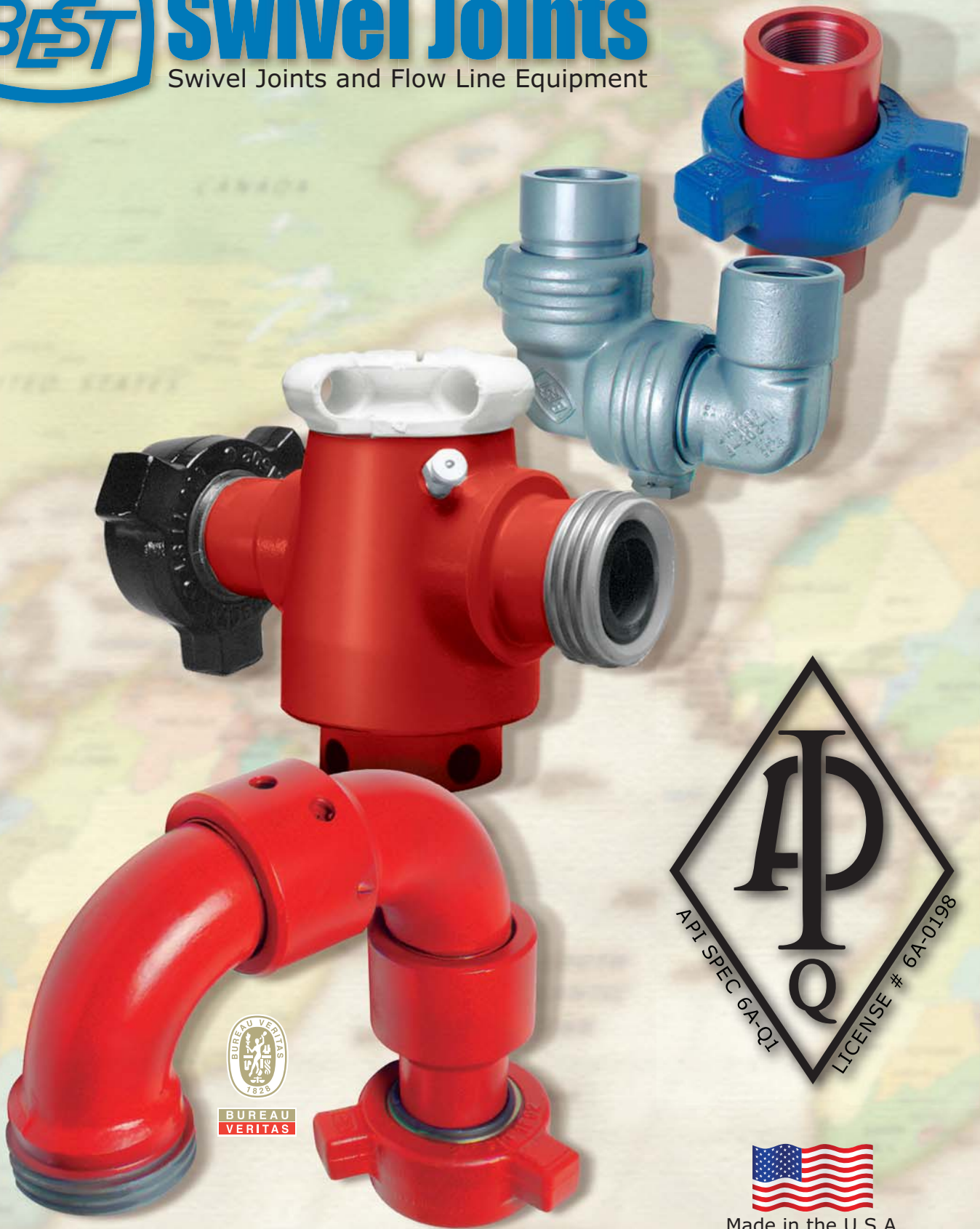

Swivel Joints

Swivel Joints and Flow Line Equipment



BUREAU
VERITAS



Made in the U.S.A.



BEST SWIVEL JOINTS, L.P.

BEST SWIVEL JOINTS has served the petroleum industry for over forty years and is the world's second oldest manufacturer of swivel joints and related flow line equipment. From swivel joints to hose loops, from pup joints to hammer unions and plug valves, **BEST** manufactures a large family of products at very competitive prices. With distributing agents in virtually every domestic oilfield location and several key oilfield areas around the world, **BEST** offers its customers prompt delivery of critical items, produced to the highest quality standards. **BEST** products are fully traceable and available with complete third party certification upon request. **BEST** products are available for both standard and sour gas service. Sour service products meet or exceed current **NACE** and **API** standards. In recent years **BEST** has expanded its product offerings to better serve its customers. **BEST's** products now include:

Hammer Unions
Threaded & Butt weld



Swivel Joints
Tri Race Technologies



Pup Joints
Threaded, NPST
& Integral



Plug Valve
Threaded, Union End,
Flanged End



CERTIFICATIONS



**PRODUCT CERTIFICATE
OF TYPE APPROVAL**

AMERICAN PETROLEUM INSTITUTE 6A LICENSE

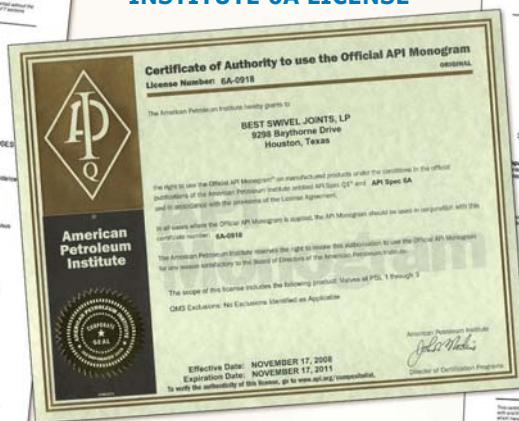

Q1 COMPLIANT



**PRODUCT CERTIFICATE
OF TYPE APPROVAL**



EXTRA HIGH-PRESSURE LONG RADIUS SWIVEL JOINTS

TRI RACE SWIVEL JOINTS

BEST tri race code red swivel joints are designed for the critical service conditions that exist in fracturing, cementing, acidizing, and well testing. They are available in 1" through 4" sizes with 15,000 PSI working pressure and 22,500 PSI test pressures. They come with 1502, 1002, and 602 union ends for fast, easy make-up. **BEST** tri race code black swivels are available in 10,000 PSI working pressure with female line pipe thread end connections.

FEATURES

- Long radius design provides lower vibration and reduced abrasion in corrosive, high rate pumping applications.
- Precision machined from forged alloy materials that are heat treated for longer service life.
- Three ball bearing raceways that more evenly share moment loads.
- Elastomeric instream packings that are compatible with today's fluids and designed to stay in place even in high velocity applications.
- Available for H2S Service @ 10,000 PSI W.P.

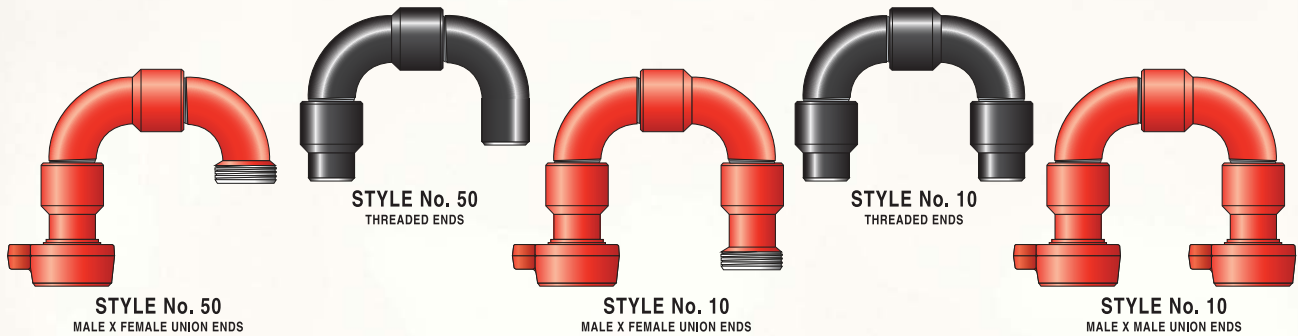
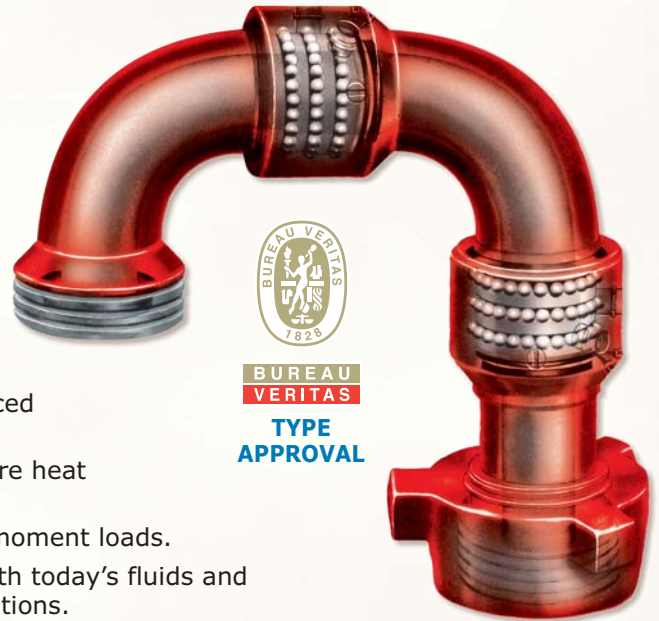

SWIVEL JOINT REFERENCE CHART

Models	Color-Coding	Cold Working Pressure (psi)	Material	End Connections	Sizes								Notes	
					3/4	1	1-1/4	1-1/2	2	2-1/2	3	4		
High-Pressure Swivel Joints BSR	Dark Blue	3,000	Carbon Steel	Threaded	•	•	•	•	•	•	•	•	•	1
	Silver	6,000		Threaded	•	•	•	•	•	•	•	•	•	1
Long Radius Swivel Joints	Olive Green*	10,000	Alloy Steel	Figure 1502 Union		Sour Gas		Sour Gas	Sour Gas		Sour Gas	Sour Gas	2	
	Black	10,000	Alloy Steel	Female Line Pipe Threads					•				3	
	Red*	15,000	Alloy Steel	Figure 1502 Union		•		•	•		•	•	1	

* BUREAU VERITAS CERTIFIED

SWIVEL JOINT NOTES

All body materials meet ASTM or AISI standards. Consult factory for special sizes, styles, end connections or package units.

1. Furnished with nitrile packing and brass anti-extrusion ring.
2. Furnished with fluoroelastomer packing and stainless steel snap in races. **BEST** does not warrant the performance of any elastomer seal for sour gas service.
3. Power make up must be used for line pipe threaded connections to achieve rated cold working pressure.

Sour Gas Service

BEST manufactures sour gas swivel joints in accordance with the National Association of Corrosion Engineers (NACE) Standard MR-01-75 and the American Petroleum Institute's (API) Standard RP-14-E. These swivel joints are specially heat-treated and inspected for controlled hardness, Fluoroelastomer packing is used to isolate the races and bearings from line fluid.



BUREAU VERITAS



STEEL HOSES

BEST cementing and circulating all steel flexible hoses offer the widest range of proven designs for today's demanding requirements.

BEST hoses are available for all your requirements; 6,000 to 15,000 PSI.

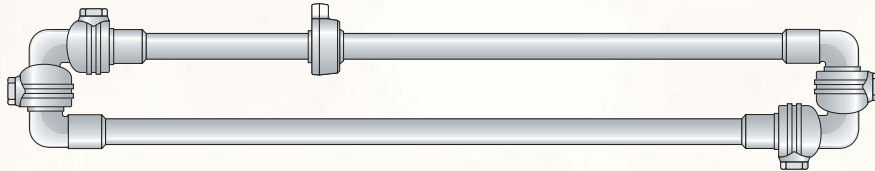

BEST BSR-6
High-Pressure Hose
Style 50 Swivel Joints
Threaded Construction

BEST TLR-10
Long Radius Hose
Style 50 Swivel Joints
Threaded Construction



BEST TLR-15
Long Radius Hose
Style 50 Swivel Joints
Non-Pressure Seal Construction

* Available for H2S Service
@ 10,000 PSI W.P.

BEST ITR-15
Long Radius Hose
Style 50 & Style 10
Swivel Joints
Integral Construction

* Available for H2S Service
@ 10,000 PSI W.P.

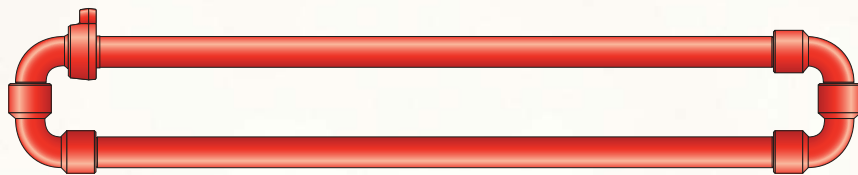

BUREAU
VERITAS



PUP JOINTS

BEST offers a complete selection of pup joints up to 15,000 PSI in standard service and up to 10,000 PSI in sour gas service.

BEST Pup Joints are available in 1" through 4" sizes with threaded or non-pressure seal threads in lengths up to 20 feet.

Please consult our factory for specific weights, dimensions and prices.

BEST's Integral Pup Joints are available in 2" and 3" sizes up to 15 feet.



Whether your service requirements run from economical water lines to the most severe abrasive service you can count on running them through **BEST**.



BUREAU
VERITAS



PLUG VALVES

BEST manufactures plug valve lines in 1" through 3" sizes. These valves are available from 5,000 through 20,000 PSI in both standard and H2S service. We offer a wide variety of popular end connections including union ends, male and female line pipe threaded ends, and flanged end connections. **BEST** is API Spec 6A licensed and can manufacture valves to PSL 1 through PSL 3 as required.

15,000 p.s.i.
Union End Valve



15,000 p.s.i.
Male Line Pipe
Threaded Valve

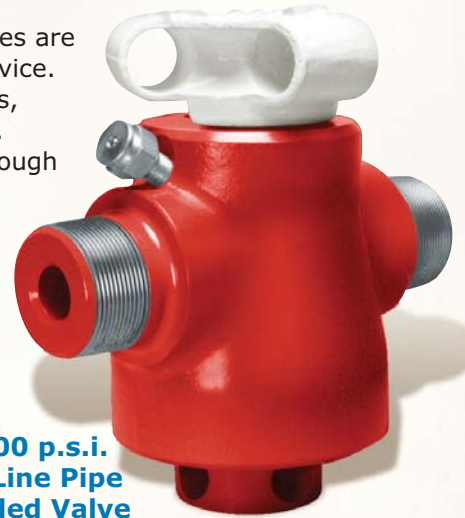

10,000 p.s.i.
Flanged End Valve



TOTALLY LUBRICATED VALVES



BEST manufactures lubricated ("TL") valves in sizes 1" through 3". These valves, which are unique to **BEST**, contain mechanisms to provide lubrication between the plug and the insert, thus increasing the life of the valves as well as repair parts, while at the same time creating a nitrogen tight seal. The components of these valves are interchangeable with parts from valves of other major manufacturers and thus can be used to retrofit existing valves. Additional benefits include less leaks at lower (below working) pressure and better lubrication thus promoting longer life of valves and their components. The special top and bottom grease fittings allow faster and more complete regreasing than with standard valves.



UNIONS

BEST Hammer Unions have long provided the fast make-up and break-out capability needed in the oilfields around the world. **BEST** unions are manufactured with line pipe threads, butt weld or nonpressure-seal thread ends. **BEST** offers a wide range of sizes and working pressures to fit our customers requirements for both standard and sour gas service.

Detachable Nut Kit

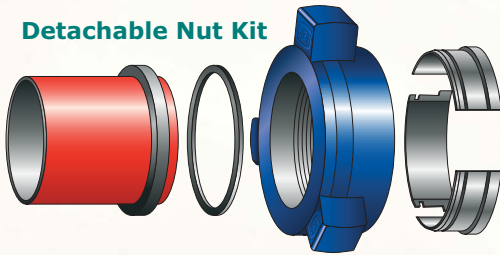

UNIONS Figure No.	WORKING Pressures (psi)	COLOR CODES		AVAILABLE SIZES						
		SUBS	NUT	1"	1-1/2"	2"	3"	4"	5"	6"
100	1,000	Yellow	Black			•	•	•		•
200	2,000	Gray	Blue	•		•	•	•		•
206	2,000	Gray	Blue	•		•	•	•		•
400	4,000	Red	Black			•	•	•		
602	6,000	Orange	Black	•	•	•	•	•		
607	6,000	Silver	Red		•	•				
1002	10,000	Blue	Red	•	•	•	•	•	•	
1003	10,000	Dark Green	Black					•	•	
1502	15,000	Red	Blue	•		•	•	•		



INTEGRAL FITTINGS

BEST manufactures a wide range of integral union end fittings from Crossovers/Changeovers to Ells, Tees and Crosses. These are available in 2" and 3" sizes in a variety of end connections in both standard and sour gas service.

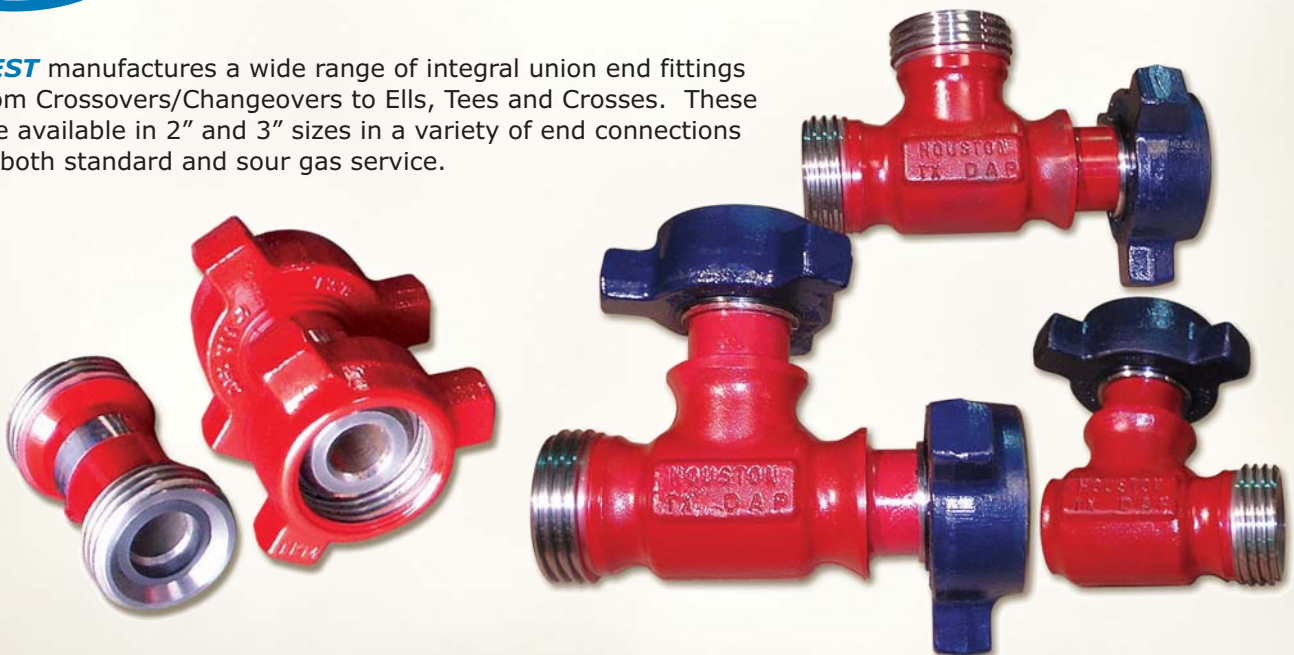



HIGH PRESSURE SWIVEL JOINTS

Available in sizes 3/4" through 4" 6,000 PSI non-shock cold working pressure, **BEST SWIVEL JOINTS** offer:

- Minimum flow restriction
- Heavy duty hex head style ball loading plug
- Grease retainer ring (insures clean ball race)
- Standard packing units (operating temperatures to 255°F) high temperature packing units (operating temperature to 450°F)
- Superior hardened ball races insure uniform surface hardness and depth for longer life under severe thrust and radial loading.

Standard swivel joints are provided with API line pipe threads. Other end connections are available on special order.

BEST sizes are available in eight styles, for 360° rotation in one, two or three planes.

All component parts and all styles of the HP-6,000 are interchangeable with similar parts by other major manufacturers. Consult factory for details.

BEST SWIVEL JOINTS usages include fluid handling, mud lines, rotary and circulating hoses. For the best flexibility under high pressure, specify **BEST HIGH PRESSURE SWIVELS JOINTS**.

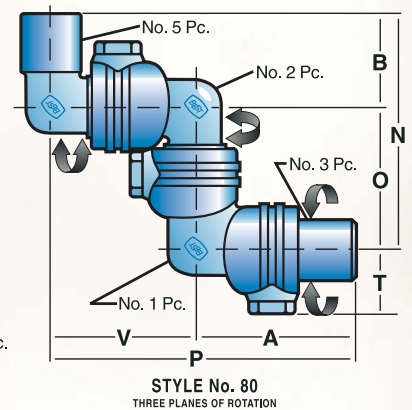
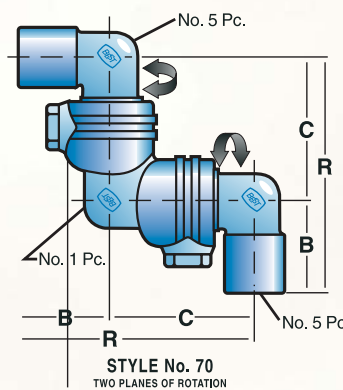
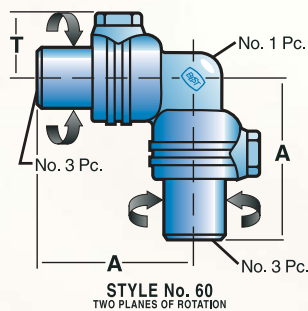
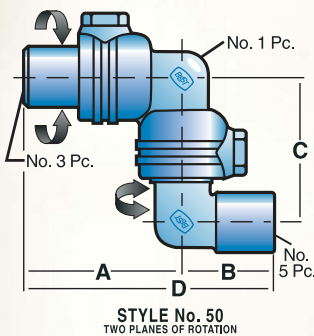
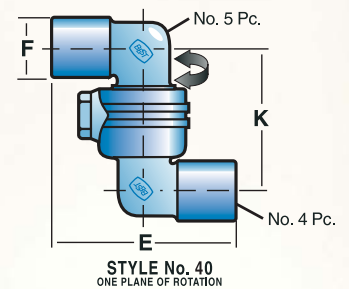
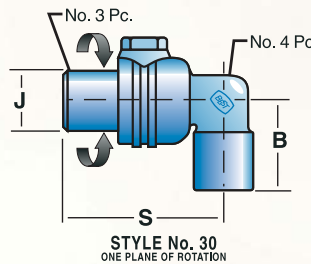
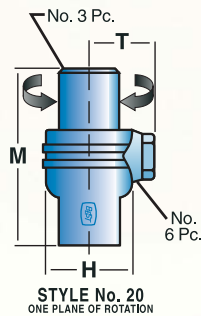
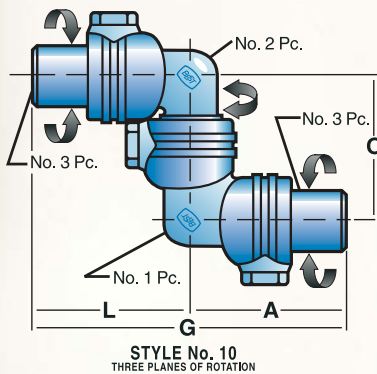

SWIVEL JOINT THREADED END SIZES

SIZE(in)	A	B	C	D	E	F	G	H	J	K	L	M	N	O	P	R	S	T	V
3/4 - 1	4 ⁵ / ₈	2 ²³ / ₃₂	4 ⁷ / ₃₂	7 ¹¹ / ₃₂	5 ⁷ / ₁₆	1 ³ / ₄	9 ¹ / ₄	2 ⁷ / ₁₆	1 ³ / ₄	4 ⁷ / ₃₂	4 ⁵ / ₈	5 ³ / ₁₆	6 ¹⁵ / ₁₆	4 ⁷ / ₃₂	8 ²⁷ / ₃₂	6 ¹⁵ / ₁₆	4 ⁵ / ₈	1 ⁷ / ₈	4 ⁷ / ₃₂
1 1/4 - 1 1/2	4 ²³ / ₃₂	3 ³ / ₁₆	4 ⁹ / ₃₂	7 ²⁹ / ₃₂	6 ³ / ₈	2 ¹ / ₂	10 ¹ / ₃₂	2 ⁷ / ₈	2 ³ / ₈	4 ⁹ / ₃₂	5 ⁵ / ₁₆	5 ¹⁵ / ₃₂	7 ¹⁵ / ₃₂	4 ⁹ / ₃₂	9 ⁹ / ₁₆	7 ¹⁵ / ₃₂	4 ²³ / ₃₂	2 ¹ / ₈	4 ²⁷ / ₃₂
2	5 ²⁷ / ₃₂	4 ¹ / ₃₂	5 ⁷ / ₈	9 ⁷ / ₈	8 ¹ / ₁₆	3 ¹ / ₈	12 ⁵ / ₁₆	4 ¹ / ₈	3 ⁵ / ₁₆	5 ⁷ / ₈	6 ¹⁵ / ₃₂	6 ²¹ / ₃₂	10 ¹ / ₃₂	6	12 ¹¹ / ₃₂	9 ²⁹ / ₃₂	5 ²⁷ / ₃₂	2 ²¹ / ₃₂	6 ¹ / ₂
3	8 ⁵ / ₈	4 ⁵ / ₈	7 ¹⁵ / ₁₆	13 ¹ / ₄	9 ¹ / ₄	4 ⁵ / ₁₆	18 ¹ / ₁₆	5 ¹³ / ₁₆	4 ¹ / ₂	8 ³ / ₄	9 ⁷ / ₁₆	9 ¹ / ₈	12 ⁹ / ₁₆	7 ¹⁵ / ₁₆	17 ³ / ₈	12 ⁹ / ₁₆	9 ⁷ / ₁₆	3 ³ / ₈	8 ³ / ₄
4	9 ⁷ / ₈	5 ⁹ / ₁₆	9 ⁵ / ₈	15 ⁷ / ₁₆	11 ¹ / ₈	5 ¹ / ₂	20 ¹¹ / ₁₆	7 ¹ / ₁₆	5 ¹ / ₄	10 ⁹ / ₁₆	10 ¹³ / ₁₆	9 ⁵ / ₈	15 ³ / ₄	10 ³ / ₁₆	20 ⁷ / ₁₆	15 ³ / ₁₆	10 ¹³ / ₁₆	3 ⁹ / ₁₆	10 ⁹ / ₁₆

All dimensions are approximate.

BEST Swivel Joints' Flow Line Equipment



Integral Hose Loops



Sizes 2" and 3"
for Standard and H2S Service
10,000 & 15,000 PSI



Extra High Pressure Swivels

Sizes 1" - 4"
10,000 PSI to 15,000 PSI
Ball Bearing Design
Threaded and Integral Union Ends

Integral Fittings

Sizes 2" and 3"
10,000 PSI to 15,000 PSI
Ells, Tees, Crosses and Crossovers
for Standard and H2S Service



Pup Joints

Sizes 1" - 4"
6,000 PSI to 15,000 PSI
Threaded and Integral &
Non-Pressure Seal Thread



High Pressure Swivels

Sizes 3/4" - 4"
3,000 PSI to 6,000 PSI



Plug Valves

Sizes 1" - 3"
5,000 PSI to 20,000 PSI
for Standard and H2S Service



Steel Hoses

Sizes 1" - 4"
2,000 PSI to 6,000 PSI



Unions

Sizes 1" - 6"
Figures 100, 200, 206, 400,
602, 1002, 1003, 1502, 2202



Huy Minh Corporation

42c, 30-4 Street, Ward 9, Vung Tau City
S.R. Vietnam
Tel: +84-64-3593646, Fax: +84-64-3594647, Email: sales@huyminh.com